

Description

Designed to work with manifolds of all types, on 210mm centers. The thermostatic blending valve is a bolt on unit providing a quick and simple system to install.

The thermostatic blending valve is the core of the control system. It is used with flow and return manifolds to control the flow temperature of water to the underfloor heating pipework. It mixes the hot water from the boiler and supplies the water back to the UFH pipe at the correct temperature. The mixing valve operates at a lower temperature than the radiator system, between 35°C and 60°C depending on the floor construction. The water supply temperature can be adjusted according to the structure of the floor.

Technical Data	
Maximum static pressure	10 bar
Maximum temperature	85°C
Adjustable control range	35°C to 60°C
Factory pre-set	45°C (Control knob is in the adjustable position)

Dimension

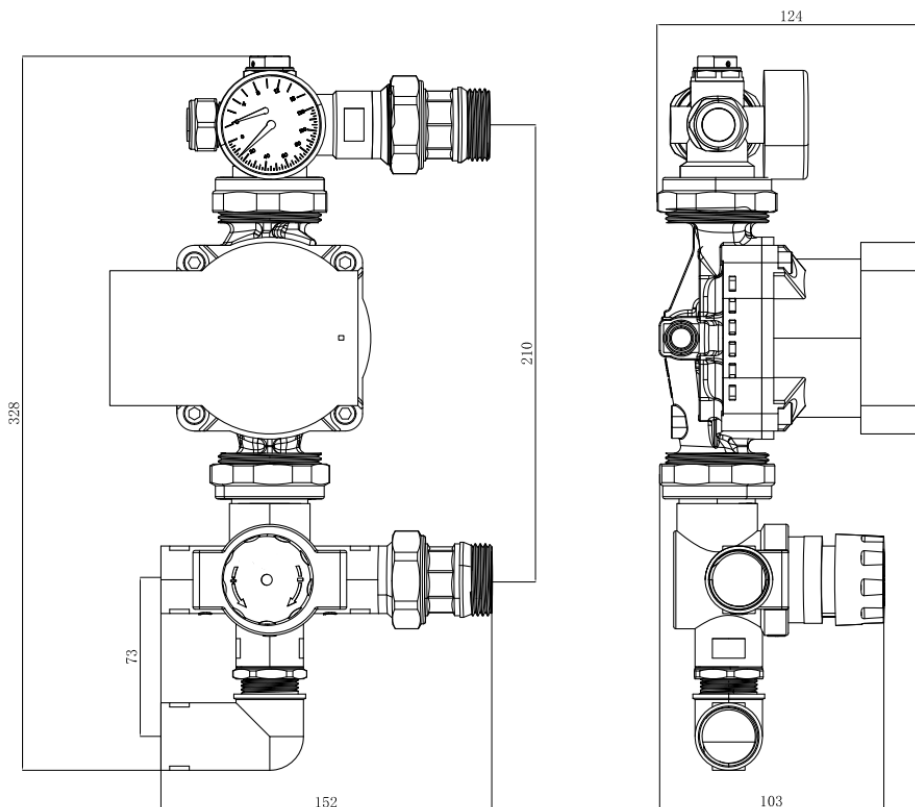

Installation

Firstly firmly fix the distribution manifolds to the wall leaving enough room beside the manifold to fit the control pack (see dimensions on Page 1). Before beginning the installation of the Thermomix Underfloor Heating Control Pack, identify all of the components in the pack.

1.1 Install the flat gasket into the connecting nut of the water-mixing system component. Then, match the connecting nut with the external thread of the water pump and tighten it. Ensure that the mixing system components, flat gaskets, and pumps are in a sealed state (note the direction arrow on the pump body).

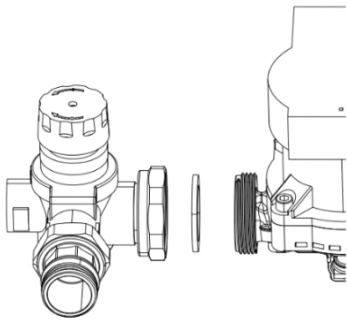

1.2 Install the gasket into the connecting nut of the water supply system component. Then, match the connecting nut with the external thread of the water pump and tighten it. Ensure that water supply system components, gaskets, and pumps are in a sealed fit.

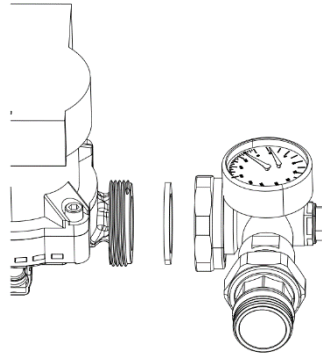

1.3 Swivel out the male unions of the mixing system and supply system. Rotate its 1" male threads into the main bar or 1" female threads of the other control unit. Use the cone ring or other sealing winding belt of the tubes to tighten and seal. Then, re-rotate the free nut of the union into the mixing system and supply system correctly to avoid any leakage.

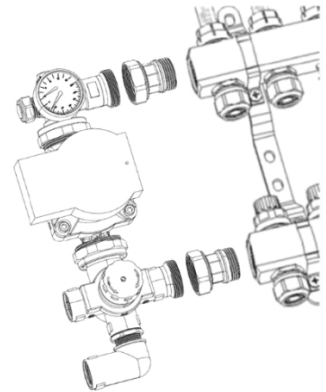

Pressure Drop Graph

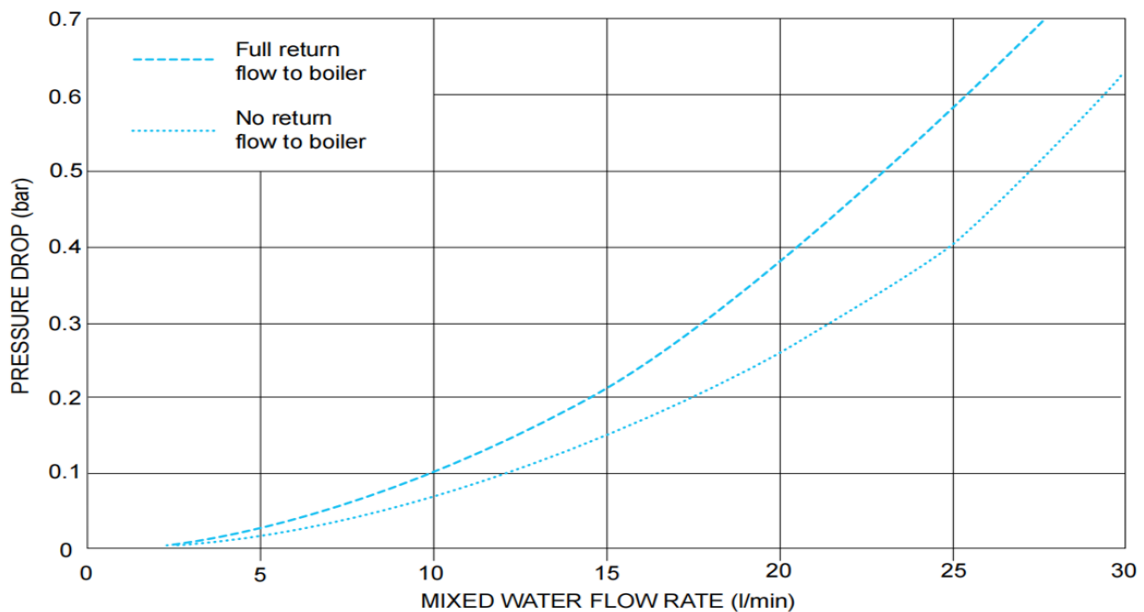

Note

If the primary circuit serving the underfloor heating is not fitted with an automatic bypass valve, it is recommended that one is installed across the flow and return pipes to improve system efficiency.

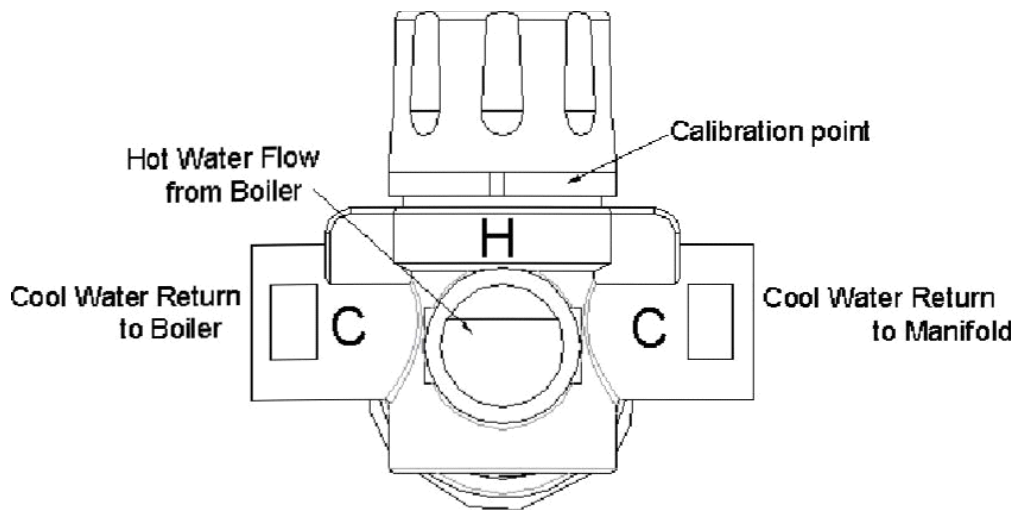

Components

PLEASE CHECK CONTENTS OF PACK BEFORE BEGINNING INSTALLATION.

1. Water supply system components (1½"F*1 M)
2. Flat gasket (45*33*3)
3. Pump (separate item)
4. Flat gasket (45*33*3)
5. Mixed water system components (1½"F x 1"M) x 3/4"F)
6. Connection elbow (3/4"F*3/4M)

